

Industrial Grade Duplex Receptacle 2-Pole, 3-Wire 15A/250V, 6-15R



Model No.: 61571

Description: Enerlites' Industrial Grade Receptacles are rated for variety of standard configuration and its smooth face design does not collect dirt. Each duplex is equipped with break-off plaster ears and tabs to allow for easy alignment and 2-circuit conversion. All duplex receptacles are designed with thermoplastic construction and feature a shallow build for maximum wiring room

Features:

- 15 amp/250-Volt
- Flammability UL94, V2 Rating.
- With ears; straight blade; side wired; steel strap
- NEMA 6-15R, 2P and 3W
- Shallow design for maximum wiring room

Specifications:

Type	Two Pole
Color Availability.....	White
Grounding.....	Grounding
Amperage.....	15Amp
Voltage.....	250V
Termination.....	Rear and Side Wired
Thermoplastic Cover and Body	
Standards and Certifications.....	UL Listed

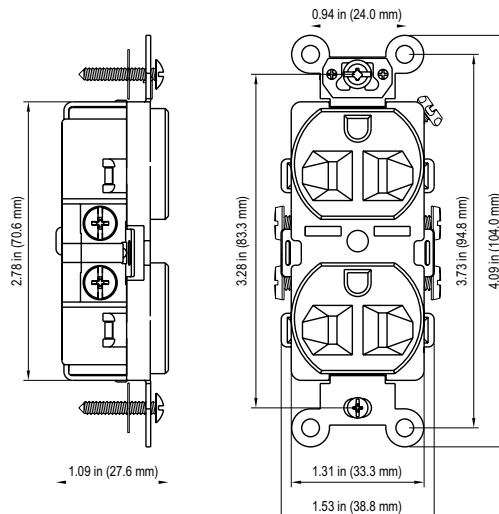

Testing & Code Compliance



Enerlites, Inc.

www.enerlites.com

Phone: 949-756-0536 Fax: 949-756-0528 e-mail: sales@enerlites.com