

SCSS : LED Surface Canopy Square



| | |
|----------------|---------|
| project name | type |
| catalog number | |
| comments | voltage |
| approved by | date |

40/57
watts

4,803/
6,313
lumens

110+
lpw

70+
CRI

Features

- Shallow design housing combines contemporary aesthetics with LED performance
- Solid die-cast aluminum construction
- Impact-resistant polycarbonate lens
- Unique quick mount design
- UV stabilized bronze powder coat finish
- Extremely low profile is ideal for confined spaces
- 5 year limited warranty

Performance

- 50,000 hour life
- Maximum ambient operating temperature 104°F (40°C)
- UL/cUL Listed for wet locations
- 5000K CCT
- CRI: >70
- Input voltage: 120-277V

Applications

- Strip malls
- Entryways
- Garages
- Plazas
- Utility Closets
- Public Restrooms
- Eaves

Ordering Information

| Order Code | Item # | Lm | W | CCT | CRI | Life/Hrs | V | Finish | DLC |
|--------------|---------------|-------|-----|-------|-----|----------|----------|--------|-----|
| 09746 | SCSS-1C-50K-U | 4,803 | 40W | 5000K | 70+ | 50,000 | 120-277V | Bronze | ✓ |
| 09747 | SCSS-2C-50K-U | 6,313 | 57W | 5000K | 70+ | 50,000 | 120-277V | Bronze | ✓ |

✓DesignLights Consortium® Qualified



SCSS : LED Surface Canopy Square

Dimensions

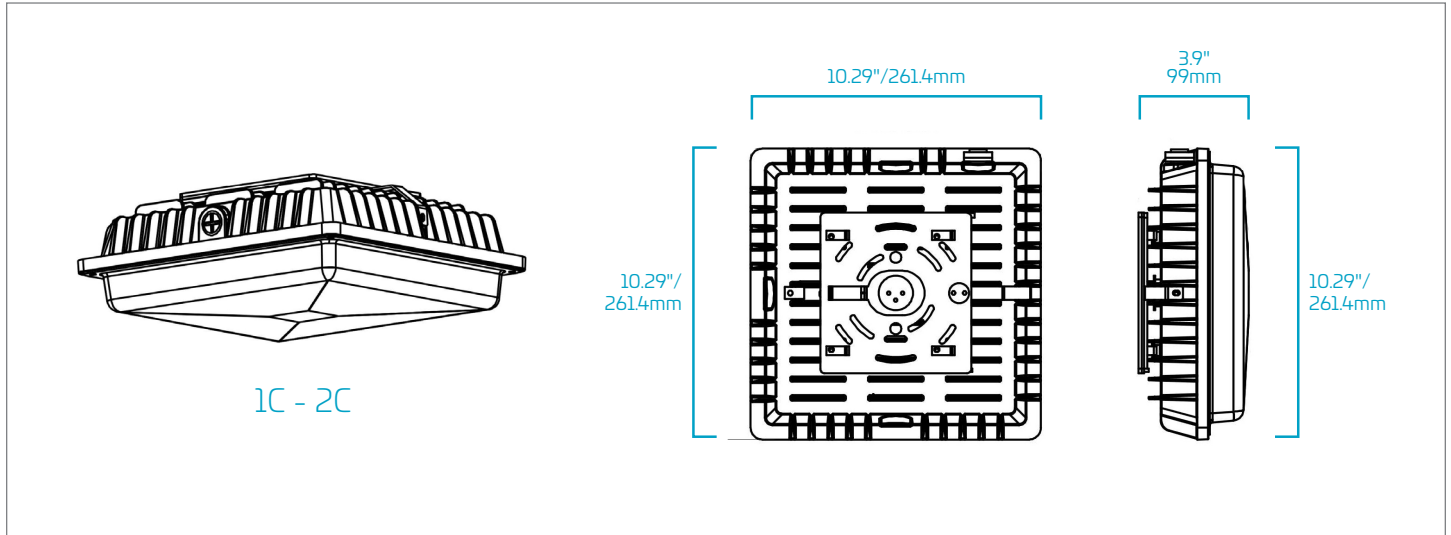

Accessories (Sold Separately)

| Order Code | Litespan Part # | Description |
|--------------|------------------|--------------------------------|
| 09849 | FHSCP-UNV-5WL | 5W Emergency Battery Backup |
| 09851 | FHSCP-UNV-7.8WL | 7.8W Emergency Battery Backup |
| 09850 | FHSCP-UNV-10.7WL | 10.7W Emergency Battery Backup |
| 09852 | FHSCP-UNV-13.7WL | 13.7W Emergency Battery Backup |
| 09854 | FHSCP-UNV-17WL | 17W Emergency Battery Backup |



watch > like > follow

