

SCST : LED Slim Canopy



project name	type
catalog number	
comments	voltage
approved by	date

120
watts

12.9K
lumens

107
lpw

5000K
CCT

Features

- Proprietary binned LED chips provide uniform color consistency
- Multiple knockouts allow for mounting to recessed outlet boxes or directly to surfaces (when used with optional junction box)
- Internal aluminum heat sink lowers operating temperatures for extended life
- Lifetime >20 years based on 8 hours of use a day
- Polycarbonate shatter-resistant lens
- Polyester powder-coated cast aluminum housing for durability and resistance to dirt and insects
- 5 year warranty

Performance

- 12,955lm @ 120W (107.6 lpw)
- 60,000 hours (L70) life
- -22°F to 104°F (-30°C to 40°C) operating temperature
- IP65 rated for wet locations
- CRI > 70
- Input voltage: 100-277V
- Power Factor: > 0.99

Applications

- Gas station canopies
- Bank drive-thru canopies
- Loading docks
- Mass transit depots

Ordering Information

Order Code	Item #	Lm	W	CCT	CRI	Life/Hrs	V	HID Equivalent	DLC
09675	SCST-4C-50K-U	12,955	120W	5000K	70+	60K	100-277V	400W MH	✓

✓DesignLights Consortium® Qualified



SCST : LED Slim Canopy

Dimensions

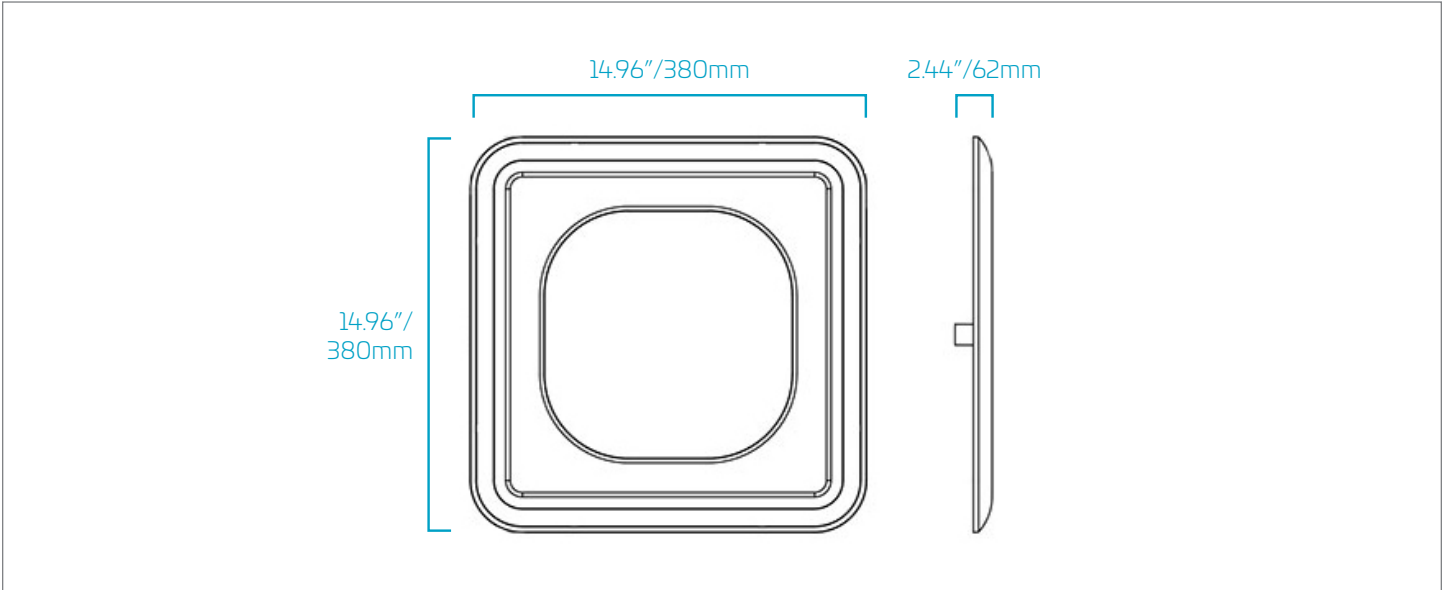

Accessories (Sold Separately)

Order Code	Litespan Part #	Description
09853	SCST-JBOX	Kit, Junction Box with 3/4 inch NPT Stem

*For some applications, optional external junction box is required for use

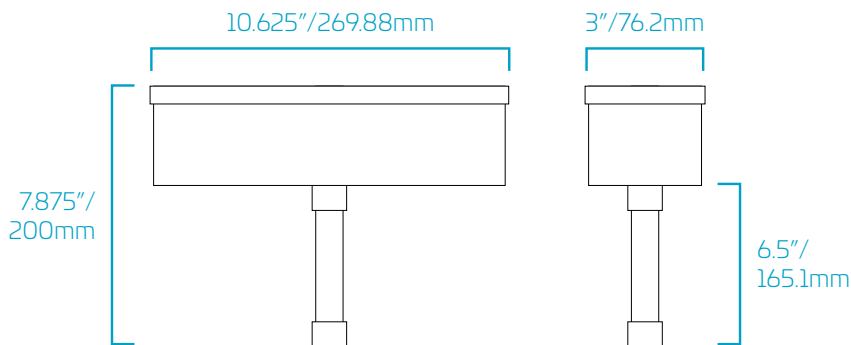

watch > like > follow

