

LEDPNL2X2-PRM-CP

Premium Performance 2x2
Ultra-Thin Edge-Lit LED Panel



Project:	
Type:	
Catalog #:	



STANDARD



The premium-performance, ultra-thin, edge-lit LED panel (LEDPNL2X2-PRM-CP) series offers industry-leading lumens per watt (LPW). This family of luminaires is designed to deliver general ambient lighting in a variety of indoor settings, including schools, offices, hospitals and stores, and is the perfect choice for both new construction and retrofits. This high-efficacy luminaire provides long-life and uniform illumination, as well as standard 0-10 vdc dimming capability.

FEATURES

- Available in 3000k (warm white), 3500k (warm/neutral white) 4000k (neutral white) & 5000k (cool white) color temperatures.*
- Long-life LEDs provide 199,000 hours of operation with at least 70% of initial lumen output (L_{70}).^{**}
- LEDPNL2X2-20W provides 2,730 luminaire lumens (124 lumens per watt, LPW) at 3000k; 2,754 luminaire lumens (125 LPW) at both 3500k; 2,769 luminaire lumens (126 LPW) at 4000k, and 2,799 luminaire lumens (127 LPW) at 5000k.*
- LEDPNL2X2-32W provides 4,016 luminaire lumens (126 LPW) at 3000k; 4,079 luminaire lumens (127 LPW) at both 3500k; 4,109 luminaire lumens (128 LPW) at 4000k, and 4,170 luminaire lumens (130 LPW) at 5000k.*
- Uniform illumination with no visible LED pixilation.
- Universal 120-277 AC voltage (50-60Hz) is standard.
- 0-10vdc dimming capability is standard.
- Power factor > 0.90.
- Total harmonic distortion < 20%.
- Color rendering index > 80.
- Aluminum housing.
- PMMA (polymethyl methacrylate) light guide panels for optimal light distribution, efficiency and longevity.
- Easy installation in new construction or retrofit.
- Standard earthquake clips provide secure installation in grid ceilings.
- Standard mounting options include recessed mounting in grid ceilings, or suspended mounting using attached hanging brackets. For mounting in plaster or other hard ceiling, see Mounting Kits.

* Contact factory for other color temperatures and lumen packages.
** L_{70} hours are IES TM-21-11 calculated hours.

WARRANTY & LISTINGS

- cULus for damp locations and insulated ceilings (IC-rated). Suitable for ambient temperatures from -20°C to 50°C (-4°F to 122°F).
- DLC premium approved.
- Flicker-free per IEEE1789-2015 (no observable adverse effects of flicker at 100% light output level).
- Complies with RoHS (Restriction on Hazardous Substances) requirements.
- Complies with FCC Part 15, class B.
- Complies with EN61000-4-5, surge immunity protection (1kV).
- 5-year warranty of all electronics and housing.

MOUNTING KITS

 See below for details

- Optional Surface Mount Kits (LEDSMKT-22) and Flange Mounting Kits (FLANGEKIT22-ET) provide for installation on plaster or other hard ceilings.
- Optional Cable Mounting Kits (LEDPNL-CMK) provide additional security, as well as suspended mounting.

DIMENSIONS

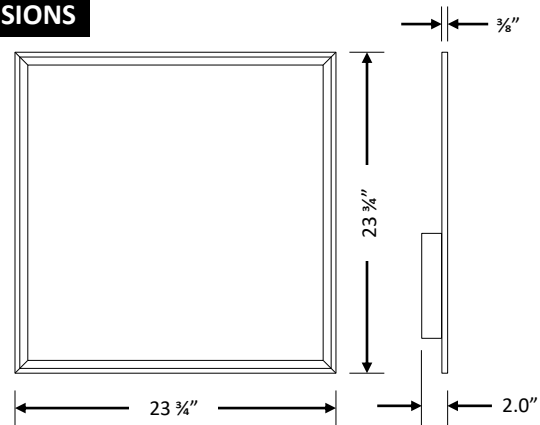

Weight: 9 1/2 lbs.

ORDERING INFORMATION

Example: LEDPNL2X2-32W-3KMV-PRM-CP + LEDSMKT-22 + LEDPNL-CMK + LEDPNL-EMBRKT

Model	Luminaire Watts	Luminaire Lumens	Lumens/Watt	Color Temperature	Options (Order Separately)
LEDPNL2X2-20W	22	2,730	124	3KMV-PRM-CP = 3000k	LEDSMKT-22 = Surface Mounting Kit (2x2)
		2,754	125	35KMV-PRM-CP = 3500K	FLANGEKIT22-ET = Flange Mounting Kit (2x2)
		2,769	126	4KMV-PRM-CP = 4000k	LEDPNL-CMK = Cable Mounting Kit, Quantity 6, 1 meter long, 1/16" diameter, with spring clips & adjustable, locking ceiling attachment
		2,799	127	5KMV-PRM-CP = 5000k	
LEDPNL2X2-32W	32	4,016	126	3KMV-PRM-CP = 3000k	LEDPNL-EMBRKT = Bracket for emergency battery backup unit
		4,079	127	35KMV-PRM-CP = 3500K	
		4,109	128	4KMV-PRM-CP = 4000k	
		4,170	130	5KMV-PRM-CP = 5000k	

LEDPNL2X2-PRM-CP

Premium Performance 2x2
Ultra-Thin Edge-Lit LED Panel



ELECTRICAL DATA

Model	Color Temp.	CRI ¹	Luminaire Lumens	Luminaire Watts	Lumens Per Watt	Input Voltage ²	Input Current (A)			Power Factor	THD ³	L ₇₀ Hours ⁴
							120V	240V	277V			
LEDPNL2X2-20W-3KMV-PRM-CP	3000k	> 80	2,730	22	124	120-277	0.18	0.09	0.08	> 90%	< 20%	199,000
LEDPNL2X2-20W-35KMV-PRM-CP	3500k	> 80	2,754	22	125	120-277	0.18	0.09	0.08	> 90%	< 20%	199,000
LEDPNL2X2-20W-4KMV-PRM-CP	4000k	> 80	2,769	22	126	120-277	0.18	0.09	0.08	> 90%	< 20%	199,000
LEDPNL2X2-20W-5KMV-PRM-CP	5000k	> 80	2,799	22	127	120-277	0.18	0.09	0.08	> 90%	< 20%	199,000
LEDPNL2X2-32W-3KMV-PRM-CP	3000k	> 80	4,016	32	126	120-277	0.27	0.13	0.12	> 90%	< 20%	199,000
LEDPNL2X2-32W-35KMV-PRM-CP	3500k	> 80	4,079	32	127	120-277	0.27	0.13	0.12	> 90%	< 20%	199,000
LEDPNL2X2-32W-4KMV-PRM-CP	4000k	> 80	4,109	32	128	120-277	0.27	0.13	0.12	> 90%	< 20%	199,000
LEDPNL2X2-32W-5KMV-PRM-CP	5000k	> 80	4,170	32	130	120-277	0.27	0.13	0.12	> 90%	< 20%	199,000

¹ Color rendering index.

² All 50-60Hz.

³ Total harmonic distortion.

⁴ L₇₀ refers to the number of hours at which lumen output declines to 70% of the initial level. L₇₀ hours are IES TM-21-11 calculated hours.

PHOTOMETRIC DATA

LEDPNL2X2-20W-3KMV-PRM-CP (2,730 Lumens)

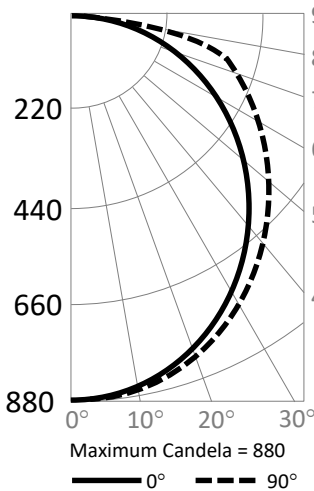

Candlepower Summary			
	0°	90°	
0°	879	879	
10°	861	861	
20°	810	815	
30°	733	743	
40°	632	653	
50°	509	561	
60°	370	469	
70°	221	372	
80°	79	195	
90°	1	0	

Zonal Lumen Summary

Zone	Lumens	% Fixture
0° – 10°	83	3.0%
0° – 20°	322	11.8%
0° – 30°	684	25.0%
0° – 40°	1,122	41.1%
0° – 50°	1,585	58.1%
0° – 60°	2,021	74.0%
0° – 70°	2,390	87.5%
0° – 80°	2,652	97.2%
0° – 90°	2,727	99.9%
90° – 180°	3	0.1%
0° – 180°	2,730	100.0%

Cone of Light

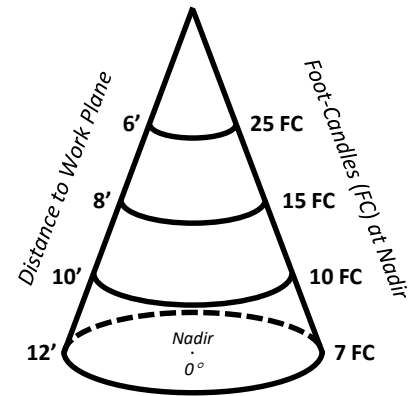

LEDPNL2X2-32W-3KMV-PRM-CP (4,016 Lumens)

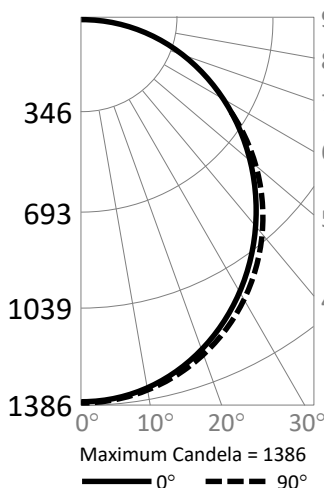

Candlepower Summary			
	0°	90°	
0°	1,377	1,377	
10°	1,341	1,374	
20°	1,260	1,312	
30°	1,136	1,207	
40°	979	1,059	
50°	788	875	
60°	573	667	
70°	351	438	
80°	141	219	
90°	1	18	

Zonal Lumen Summary

Zone	Lumens	% Fixture
0° – 10°	130	3.2%
0° – 20°	504	12.5%
0° – 30°	1,071	26.7%
0° – 40°	1,756	43.7%
0° – 50°	2,469	61.5%
0° – 60°	3,115	77.6%
0° – 70°	3,614	90.0%
0° – 80°	3,912	97.4%
0° – 90°	4,006	99.8%
90° – 180°	10	0.2%
0° – 180°	4,016	100.0%

Cone of Light

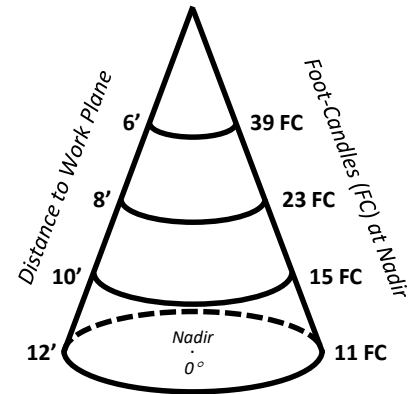

OPTIONS

- Optional surface mounting kits (LEDSMKT-22) mounts below the ceiling.
- Optional flange mounting kits provide for recessed installation on plaster or other hard ceilings. Attach Flange Mount Kit (FLANGEKIT22-ET) to ceiling joists or other stationary structures, and the panel is mounted flush to the ceiling.
- Optional cable mounting kits provide additional security, as well as suspended mounting. Attach one end of the Cable Mount Kit (LEDPNL-CMK) to luminaire earthquake clips using spring clips, and attach the other end to stationary structures using the adjustable, locking ceiling attachment (see picture below right).
- Optional bracket for emergency battery backup unit (LEDPNL-EMBRKT) provides structural support to prevent panels from bending when the battery backups are installed.

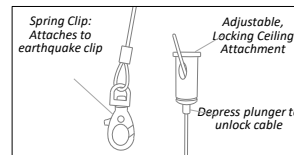
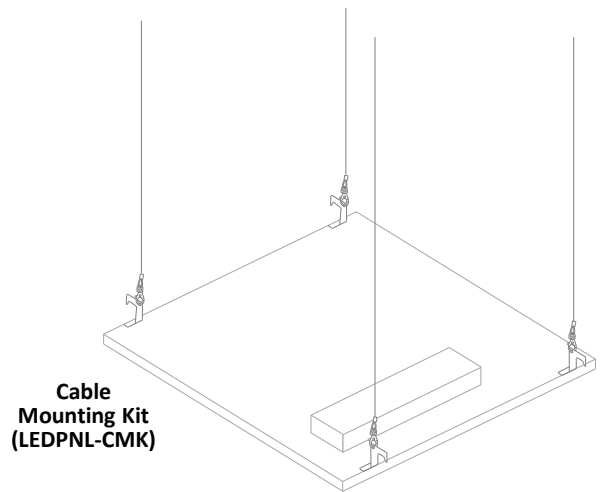
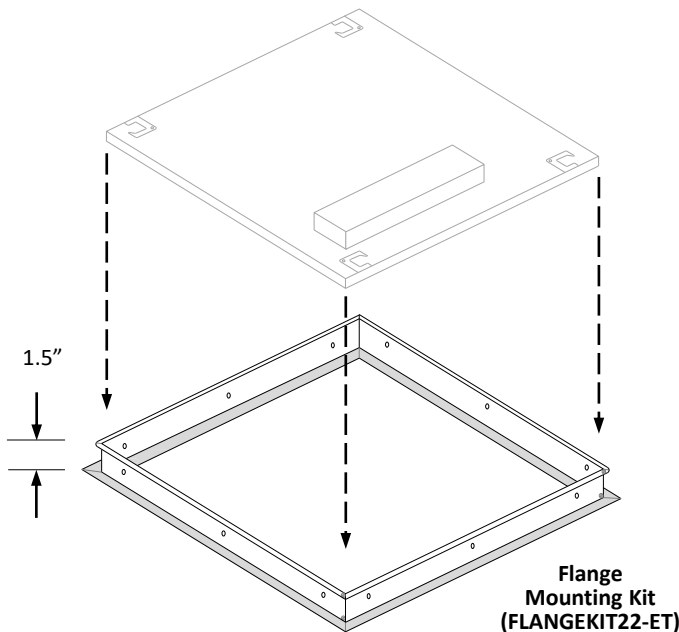
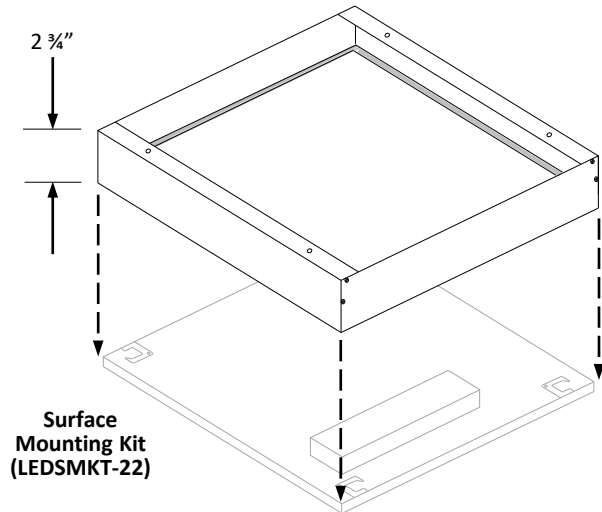

- Cable Mount Kit:
- Spring Clip
 - Adjustable, locking ceiling attachment

