

LED LOD-SL V2 Strip Light Series

2 Foot



8 Foot



FEATURES

- Linkable:
 - 2FT: up to 40 pieces together
 - 4FT: up to 20 pieces together
 - 8FT: up to 10 pieces together
- IP20 rated
- 50,000 hours lifetime

SUITABLE APPLICATIONS

- Warehouses
- Stadiums
- Factories
- Parking Lots
- Shopping Malls
- Supermarkets
- Logistic Centers
- Auto dealerships

CONSTRUCTION:

Static sprayed matte white. PC Aluminum. PMMA lens cover.

OPTICAL SYSTEM:

Samsung 2835 LED chips. 120° beam angle.

WARRANTY:

5-year limited warranty. Actual performance may differ as a result of end-user environment and application.

ELECTRICAL:

Available as 120-277V input. -20°C to 50°C, -4°F to 122°F

INSTALLATION & MOUNTING:

Surface mounting.

CONTROLS & DIMMING:

0-10V dimming comes standard.



MODEL NUMBER – 4,000K / 5,000K	WATTAGE	LUMENS	EFFICACY	CRI	POWER FACTOR	THD	REPLACES
LOD-2FTSL22WDF-50K-V2-[Blank,EM]-[Blank,MS]	22W	2,989LM	135.9LM/W	80	0.9	20%	100W
LOD-8FTSL72WDF-40K-V2-[Blank,EM]-[Blank,MS]	72W	10,100LM	140.3LM/W	80	0.9	10%	250W

Series	Size	2FT Wattage	8FT Wattage	Color Temperature	Dimming	Material	Version
LOD-#FTSL	2FT = 2 foot 8FT = 8 foot	22W	72W	4000K 5000K	Dimmable	F = Frosted Lens	V2 = Version 2

MEASUREMENTS

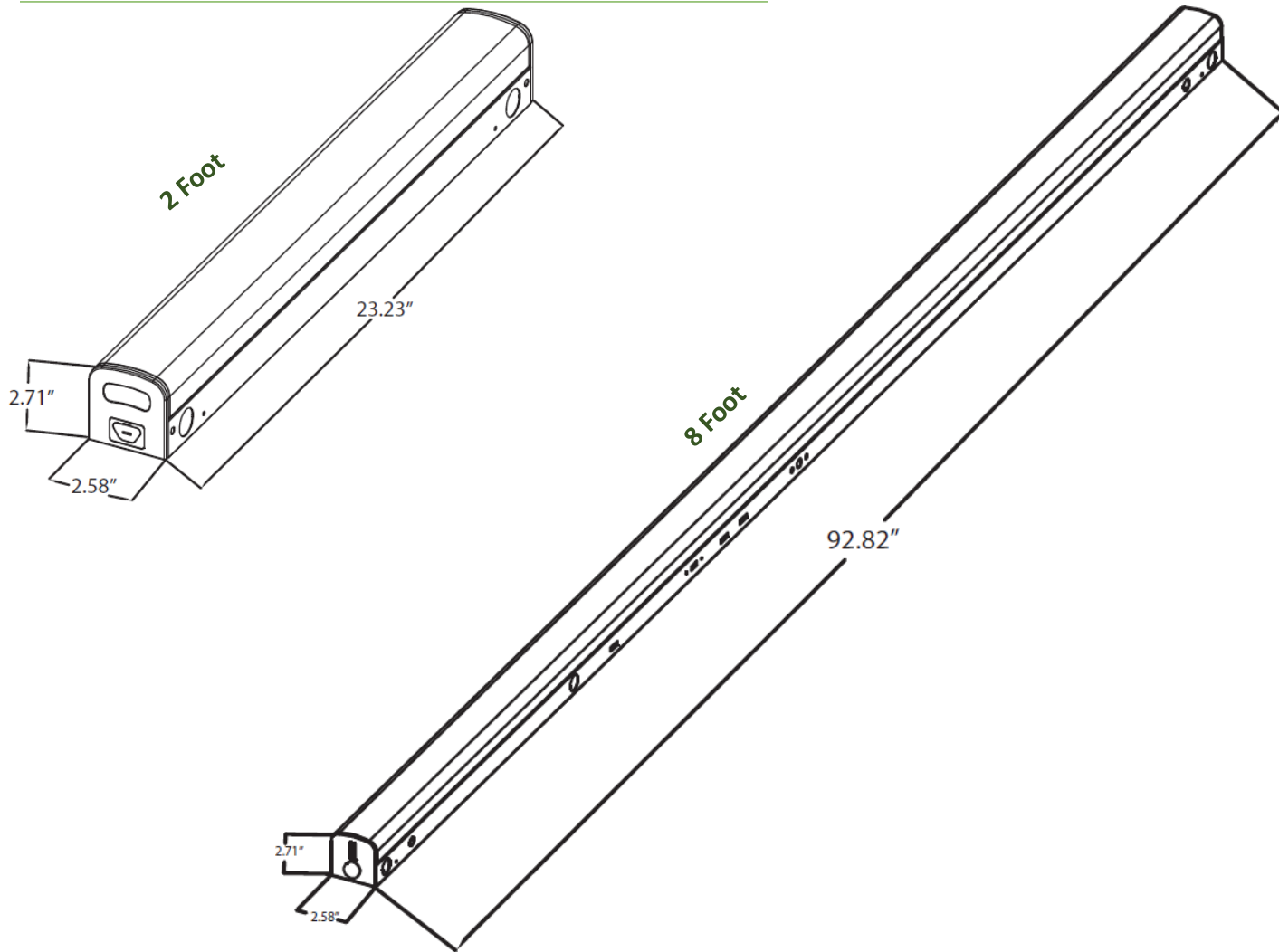

MODEL	QUANTITY	WEIGHT	UPC CODE
LOD-2FTSL22WDF-50K-V2-[Blank,EM]-[Blank,MS]	1	lbs	00815586024865
LOD-8FTSL72WDF-40K-V2-[Blank,EM]-[Blank,MS]	1	lbs	00815586024797