

## PRODUCT DESCRIPTION:

Post Top Lamps are ideal for large outdoor areas such as parking lots, corporate parks, sidewalks and retail settings.

## FEATURES:

- Philips Lumileds 3030 LED chips
- Die-cast aluminum housing
- Polyester powder-coated finish
- Rust and corrosion proof
- IP65
- 120 beam angle

## DIMENSIONS:

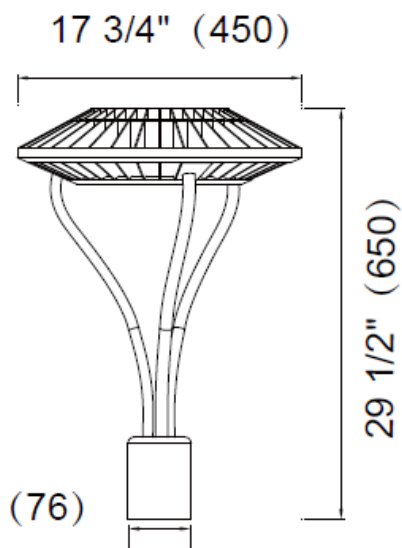

## 150W Post Top Spec

LOD-PT-150W-50K-LV-V12



### SPECIFICATIONS:

SPECIFICATION	Details
Model	LOD-PT-150W-50K-LV-V12
Input Wattage (W)	150W
Lumens Delivered (LM)	16,200LM
Efficacy (LM/W)	108LM/W
CRI	70
Lifespan	50,000 hours
Color Temperature	5,000K
Wattage Equivalent	400W – 600W
Dimmable	Yes
IP Rating	IP65
Beam Angle	120
Input Voltage	AC100-277V
Power Factor	0.95
THD	13.4%
Housing	Aluminum
Lens	Clear
Mounting	Pole Mount
Size	29.5" x 17.34" x 3"
Certification	DLC, ETL
Operating Temperature	-20°C to 50°C (-4°F to 122°F)
Environment	Outdoor
Warranty	5 years limited



