

PRODUCT DESCRIPTION:

Post Top Lamps are ideal for large outdoor areas such as parking lots, corporate parks, sidewalks and retail settings.

FEATURES:

- Philips Lumileds 3030 LED chips
- Die-cast aluminum housing
- Polyester powder-coated finish
- Rust and corrosion proof
- IP65
- 120 beam angle

DIMENSIONS:

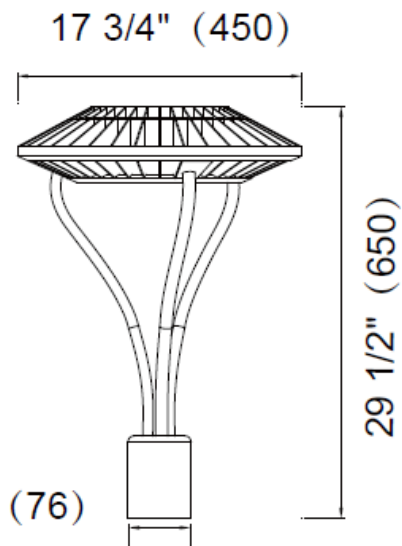

60W Post Top Spec

LOD-PT-60W-50K-LV-V12



SPECIFICATIONS:

SPECIFICATION	Details
Model	LOD-PT-60W-50K-LV-V12
Input Wattage (W)	60W
Lumens Delivered (LM)	6,750LM
Efficacy (LM/W)	107LM/W
CRI	80
Lifespan	50,000 hours
Color Temperature	5,000K
Wattage Equivalent	100W
Dimmable	No
IP Rating	IP65
Beam Angle	120
Input Voltage	AC100-277V
Power Factor	0.91
THD	18%
Housing	Aluminum
Lens	Clear
Mounting	Pole Mount
Size	29.5" x 17.34" x 3"
Certification	DLC, ETL
Operating Temperature	-20°C to 50°C (-4°F to 122°F)
Environment	Outdoor
Warranty	5 years limited



