

QS25A07RTDB-PLT

25 Foot Above Grade Round Tapered Direct Burial Aluminum Light Pole, Quick Ship

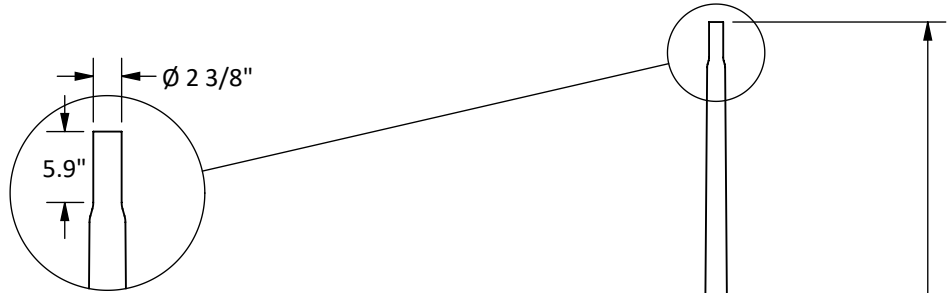

Job: _____ Client Name: _____
 Job Site: _____ State: _____ Approvals: _____ Date: _____
 Notes: _____



Standard Pole Top with 2 3/8" Tenon

- Pole Top:** 2 3/8" tenon is standard. 3" tenon or top cap options are available.
- Pole Shaft:** 25 ft. height above ground, Tapered aluminum shaft with 0.138" wall thickness. The pole shaft is constructed of seamless extruded tube of 6060 Series Aluminum Alloy.
- Handhole:** 3.35" X 15.75" handhole is located 23.6 inches above ground. Handhole cover with 2 Tamper-Resistant Screws is provided. A ground lug with set screw is located near the handhole opening for proper grounding of the pole.
- Embedment:** Embedment length is 5.2 ft. Two wire accesses 180° apart are provided 23.6" below ground line.
- Finish:** Dark Natural Aluminum.
- Warranty:** 10 Years.
- Maximum Luminaire Weight:** 100 lbs
- Weight:** 90 lbs
- Foundation design:** Foundation should be designed by an engineer familiar with local soil and wind conditions as well as local code where the pole(s) will be installed.

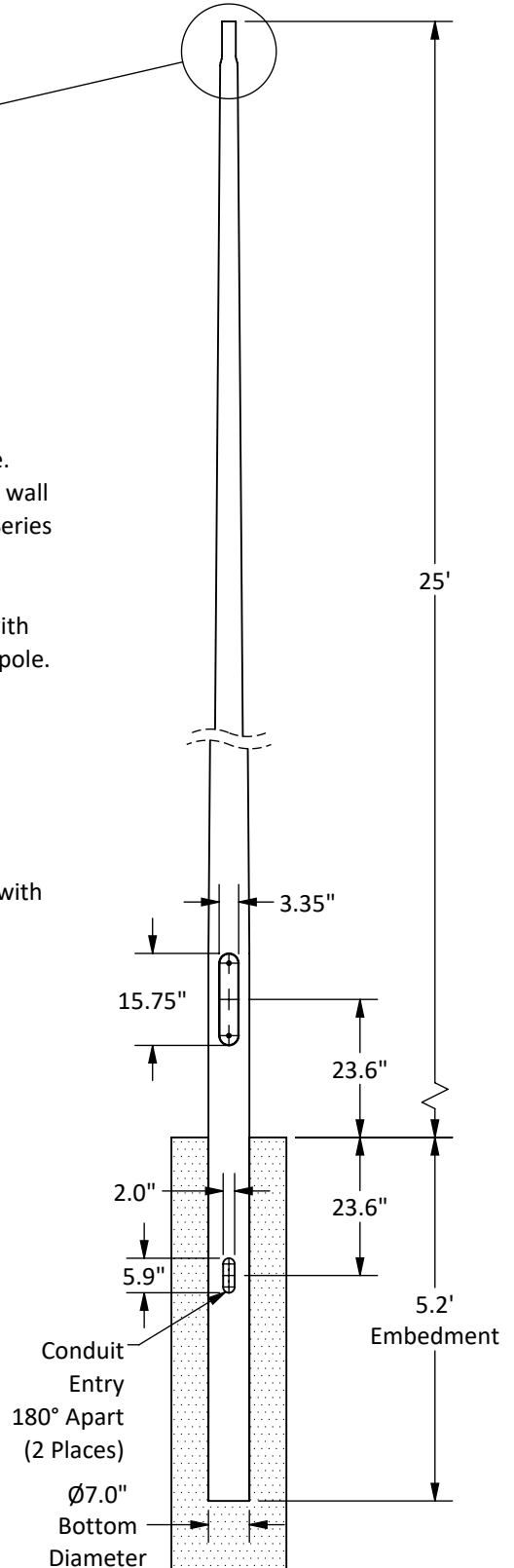

Maximum EPA per 2023 Florida Building Code							
110 mph	120 mph	130 mph	140 mph	150 mph	160 mph	170 mph	180 mph
8.3	7.1	6.3	5.0	4.1	3.2	2.9	2.3

Disclaimer: All dimensions and specifications are subject to change without any notice. Energy Light, Inc. is not responsible for any claims arising from improper loading (what is attached to the light pole), improper use, incorrect foundation design and/or installation.