

6" LED ARCHITECTURAL CAN & FRAME IN KIT



Project:	
Type:	
Catalog #:	

STANDARD



The Energy Star BL6CLED series is a 6" commercial grade architectural can & frame in kit. Built for commercial use with architectural frames and a deep cone reflector for precision light. This high-efficiency luminaire provides long life - offered in two wattages and color temperatures.

FEATURES

- Architectural frames
- C channel and flat hanger bars for tie down to ceiling grids.
- 28 Watt available in 3000K.
- 48 Watt available in 4000K.
- Junction box is mounted on the frame for easy wiring, driver access for installation, and replacement.
- Diecast aluminum heatsink dissipates heat from the LED board.
- Self-flanged aluminum reflector with a frosted lens to shield direct view of LEDs.
- Universal 120-277 AC voltage (50/60Hz)
- 0-10V dimming
- Color rendering index ≥ 80 .
- Long life LEDs - up to 50,000hours.
- Operation Temp. $-30^{\circ}\text{C} \sim 40^{\circ}\text{C}$ ($-22^{\circ}\text{F} \sim 104^{\circ}\text{F}$).

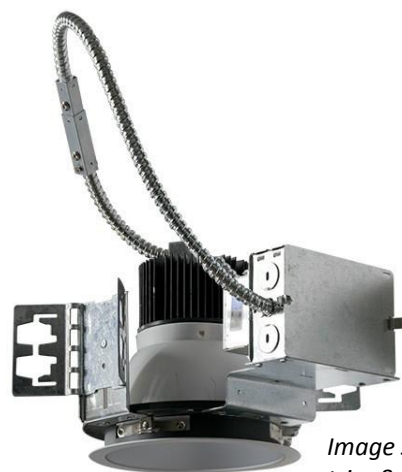
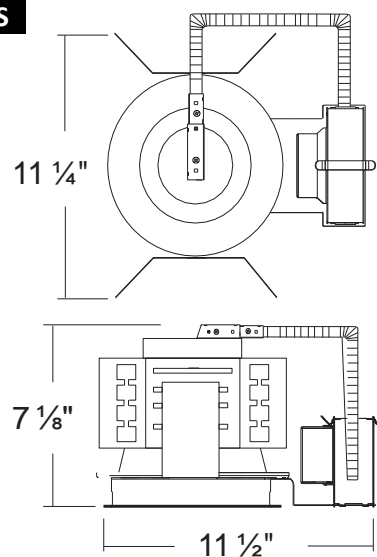

Image shown with trim & frame. Each item ordered separately.

WARRANTY & LISTINGS

- cULus Listed.
- Energy star listed.
- Suitable for wet locations (not suitable for coastal/salt water areas).
- Suitable for damp locations.
- RoHS compliant.
- 5-year warranty of all electronics and housing.

DIMENSIONS



ORDERING INFORMATION

Trim Models

Model	Color Temperature	Luminaire Lumens	Luminaire Watts	Lumens/Watt
BL6TCLD-28HZ-3K	3000k	2210	28	79
BL6TCLD-48HZ-4K	4000k	3770	48	79

Frame Models

Luminaire Wattage	Frame Required
28	BL6CLED-28A
48	BL6CLED-48A