

**DIMENSIONS:**

17.52"(DIAMETER) x 7.47"(H)

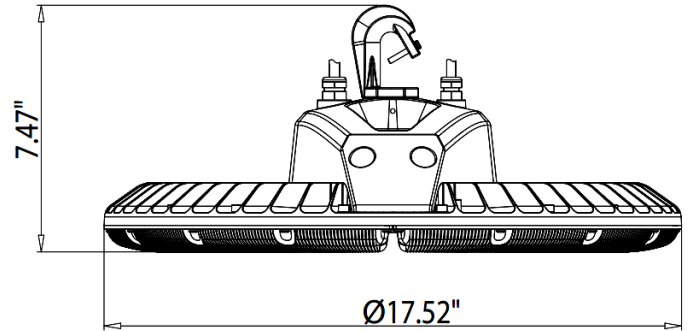

**USHB-100W-50K**  
**USHB-100W-40K**

**LED SATURN HIGH BAY**

Ideal for indoor parking lots, commercial buildings, schools, warehouse, retail centers, apartment, complexes,

**ELECTRICAL SPECIFICATIONS:**

- Voltage: 120~277VAC, 50/60 Hz
- Wattage: 100W
- Power factor: >0.90
- Total Harmonic Distortion (THD): < 20%
- Efficacy: 130LM/W

**HOUSING SPECIFICATIONS:**

- Housing: Aluminum heat sink, White finish
- Aluminum LED Board: High conductive, waterproof, aging resistant, salt mist resistance, long-life
- Cord type: 6' SJTW 18/3 AWG cable
- Operating temperature: -4°F to 122°F
- IP Rating: IP66, Suitable for Wet Locations

**CERTIFICATIONS: UL, DLC, NSF**



MODEL	WATTS	VOLTAGE	LUMENS	COLOR TEMP
USHB-100W-50K	100W	120~277VAC	13000LM	5000K
USHB-100W-40K	100W	120~277VAC	13000LM	4000K

**LIGHTING SPECIFICATIONS:**

- Dimming: 0~10V Dimming
- Total lumens: 13000LM
- Color temperature: 5000K/4000K
- CRI: >80
- Beam Angle: 110°

**WARRANTY: 5 years**

